

SARUM ELECTRONICS LIMITED

AUTOCHANGEOVER CONTROL



Sarum Electronics Limited

Clump Farm Ind Est.

Blandford

Dorset

DT11 7TD

Tel : 01258 480802

Fax : 01258 480803



AUTOCHANGEOVER PANEL

INTRODUCTION

This controller is designed :

- To automatically change from one motor to another in the event of a fault condition.
- To ensure even duty of the motors, in its "Auto" mode, switch between motor 1 and motor 2 approximately every 5 hours. Alternatively, either motor can be selected and will only switch to standby in a fault condition. A double pole switch with neon is provided to switch the unit ON-OFF, the neon in the switch is illuminated in the ON position.
- So that in the event of a fault condition, the controller will automatically switch to standby motor. The display on the front of the control will show which motor is running and which has a fault. In addition to the fault indicator, a volt free contact rated at 230V 50Hz 5A will make under fault condition and stay made until the fault is removed and the control reset by switching OFF and back ON.
- So a fault condition can be monitored by any device or devices with a volt free contact which makes in a fault situation. This can be an airflow switch, flow switch, pressure switch, thermostat, humidity switch or any other suitable device.
- With a built-in electronic timer to prevent a fault condition being shown at turn on. This timer is set for approximately 20 seconds and will prevent spurious fault switching. Only after a fault condition has been monitored for 20 seconds will the standby motor be switched on.
- For 230V 50Hz SINGLE PHASE motors with a maximum full load current of 6 AMPS each. A fuse is provided for each motor and is replaceable from the front of the controller.

STANDARD WIRING DIAGRAM FOR SINGLE PHASE MOTORS

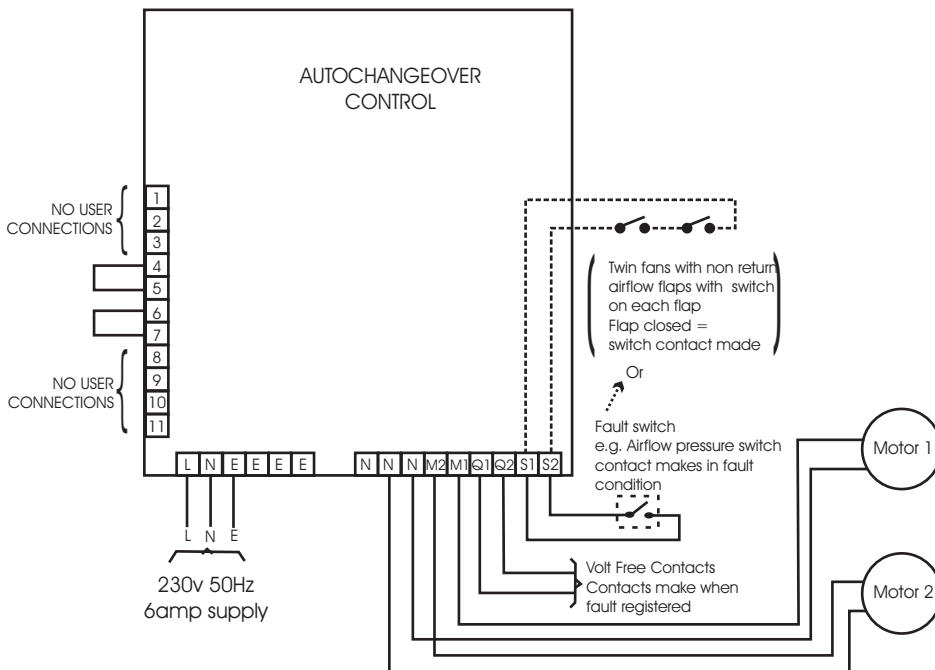

THE INFORMATION PROVIDED IN THE LITERATURE IS BELIEVED TO BE ACCURATE (SUBJECT TO CHANGE WITHOUT NOTICE). HOWEVER, USE OF INFORMATION SHALL BE ENTIRELY AT THE USER'S OWN RISK.

ENCLOSURE DETAILS

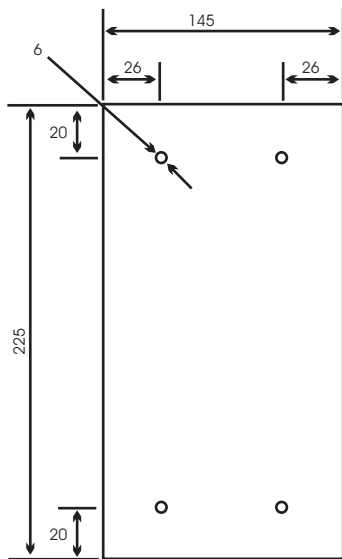

1.2mm MILD STEEL
LIGHT GREY (RAL 7035)

All measurements in mm

WIRING DIAGRAM FOR THREE PHASE MOTORS

